

tineco

PURE ONE S12 Platinum
Smart Vacuum Cleaner

Instruction Manual



*Actual product may differ from illustration.

CONTENTS

Important Safety Instructions.....	3
Overview.....	6
Product Components.....	8
Accessories.....	9
Assembly.....	11
Operation.....	13
Maintenance.....	21
Specifications.....	25
Troubleshooting.....	26
Warranty.....	28

Precautionary measures:



1. **Do not** operate the vacuum cleaner too close to heaters, radiators or other hot surfaces.



2. Before inserting the plug into the wall, make sure your hands are dry.



3. Before turning on the vacuum cleaner, safely remove any large objects from the floor or cleaning surface in order to prevent damage to the filter.



4. When you want to remove the plug from the power socket, do not use the power cable, gently pull the plug from the power socket.



5. **Do not** use this vacuum cleaner to pick-up water or liquids.

Do not use this vacuum cleaner if the battery pack housing and/or the charger housing is damaged.

Important Safety Instructions

IMPORTANT! Always switch off the cleaner before cleaning, when not in use or attempting any maintenance task. The charger must only be connected to an AC power supply at the voltage shown on the rating label. This cleaner should only be used for its intended purpose as described in this instruction manual. Never operate the cleaner without filters.

When using your vacuum cleaner, basic precautions should always be observed, including the following;

1. This appliance is not intended for use by persons (including children) with reduced physical, sensory, mental capabilities or lack of experience and knowledge, unless they have been given supervision or instruction concerning use of the appliance by a person responsible for their safety.
2. Children should be supervised to ensure that they **do not** play with the appliance.
3. To prevent electrical shock, **do not** immerse the appliance, battery or power plug into water or other liquids.
4. To prevent electrical shock, **do not** use the vacuum cleaner outdoors or on wet surfaces.
5. Always check the power cord before use, the power cord and the power adapter should be in a good condition and **must not** be damaged. If the power cord or the charger adaptor is damaged or defective, it must be replaced.
6. The appliance and charger are intended for domestic indoors use only.
7. **Do not** unplug the charger by pulling on the power cord. To unplug, grasp the power adapter, not the power cord and gently pull the power adapter from the power socket.
8. **Do not** handle or operate the appliance with wet hands. Follow electrical safety precautions at all times.
9. **Do not** attempt to change the attachments while the appliance is switched on. Use only manufacturer's recommended accessories.
10. **Do not** operate the vacuum cleaner too close to heaters, radiators and other hot surfaces.
11. **Do not** use the appliance to pick up flammable items or combustible liquids (i.e. gasoline, hot ashes, cigarettes, matches, explosive materials or anything burning) or use in areas where such substances and items may be present.
12. **Do not** use the appliance to pick up toxic materials (i.e. chlorine, bleach, ammonia).
13. **Never** operate or use the appliance without the filters in place.

14. Before vacuuming, remove any large or sharp objects from the floor or cleaning surface in order to prevent damage to the filter.
15. If the air inlet or floor head is blocked, switch off the cleaner straight away. Clear the blocked object before attempting to start the vacuum cleaner again.
16. Before carrying out any maintenance or cleaning the filters, always switch off the vacuum cleaner.
17. Keep openings away from your face and body.
18. **Do not** use the vacuum cleaner if it is damaged or broken. If connection cables are damaged, have them replaced immediately.
19. **Never** clean the vacuum cleaner or any of the electrical parts, especially the electrical connections with water or liquid cleaners.
20. **Never** attempt to make any modifications to the vacuum cleaner and charger.
21. Always store the appliance, battery and charger indoors in a cool and dry place.
22. **Do not** use the vacuum to pick up water or liquids. This cleaner is for dry household use only.
23. Use the electric power head only for vacuuming dust and dry substances in the home.
24. **Never** run over the power cable with the power head, as this may cause damage to the power cable.
25. Keep your hands away from the roller brush while the vacuum cleaner is switched on.
26. To prevent unnecessary wear on the power head, keep it moving while in operation.
27. Damage caused by improper use or by not observing the instructions in this manual will void the warranty.

Battery use and care

1. The appliance is only to be used with the charger provided with the appliance.
2. Only charge the battery inside the cleaner or the charging dock. Only use the specifically designated charger to charge the product.
3. When the appliance is not in use, keep it away from other metal objects, like paper clips, coins, keys, nails, screws or other small metal objects that can make a connection from one terminal to another. Shorting the appliance terminals together may cause burns or a fire.
4. Under abusive conditions, liquid may be ejected from the battery; avoid contact. If contact occurs, flush with water immediately. If liquid comes into contact with your eyes, seek medical help immediately.
5. **Do not** charge or store the appliance outdoors or inside the car. Only charge or store the battery in a dry indoor area where the temperature is more than 4 deg C but less than 40 deg C. The charger is for indoor use only.
6. **Never** attempt to open the battery pack for any reason. If the plastic housing of the battery casing breaks or cracks, immediately discontinue use and do not recharge.
7. The charger is **not** a serviceable part.
8. Before disposal of your battery, fully discharge your battery by running the product until it stops.
9. The cleaner contains a Lithium battery. **Do not** dispose the appliance with your local garbage. Contact your local council for instructions on how to safely dispose of the battery.
10. **Do not** use the charger to charge a non-chargeable battery.

Overview

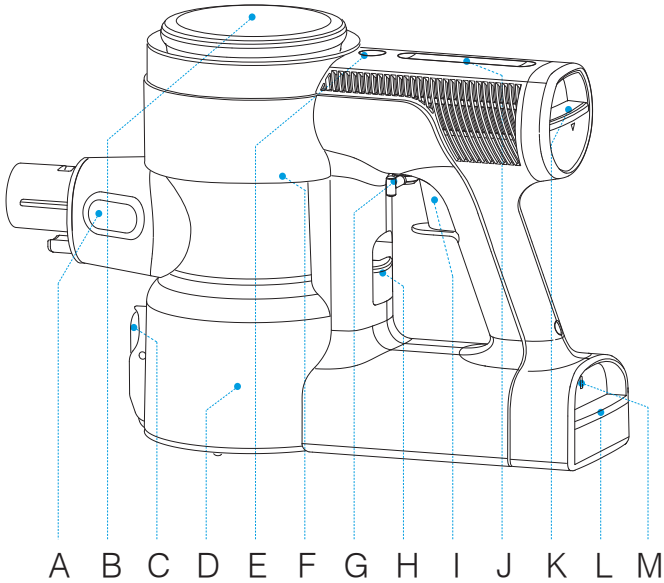





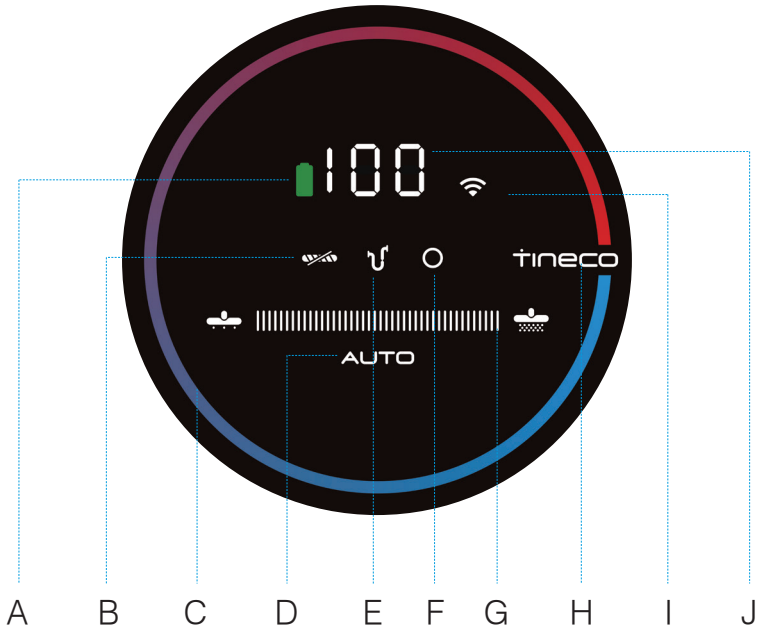





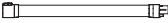



- A. Dust sensor
- B. Digital display
- C. Dust empty release button
- D. Dustbin
- E. AUTO mode
- F. WiFi reset button
(Remove the dustbin to access)
- G. Trigger lock
- H. Dustbin release button
- I. Trigger
- J. Power control slider
- K. HEPA release button
- L. Battery release button
- M. Battery indicator light

Digital Display

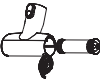

- A. Battery icon
- B. Brush roller tangled
- C. Dust monitoring loop
(Blue to red according to the dust amount)
- D. AUTO mode
- E. Air channel blocked
- F. Dust sensor malfunction
- G. Power indicator
- H. Tineco logo
- I. WiFi indicator
- J. Battery level indicator

Product Components

	Item	S12 Platinum
	Main body	<input type="radio"/>
	Tube	<input type="radio"/>
	Direct-drive LED multi-tasker power brush	<input type="radio"/>
	Mini power brush	<input type="radio"/>
	2-in-1 dusting brush	<input type="radio"/>
	Crevice tool	<input type="radio"/>
	Soft dusting brush	<input type="radio"/>
	Flexible long crevice tool	<input type="radio"/>
	LED soft-roller power brush	<input type="radio"/>
	Multi-angle folding tube	<input type="radio"/>
	Flexible extension hose	<input type="radio"/>
	Automatic pre-filter cleaning tool +Spare pre-filter	<input type="radio"/>
	Spare lithium battery	<input type="radio"/>
	Wall-mounted dock	<input type="radio"/>
	Adaptor	<input type="radio"/>
	Hair cleaning tool	<input type="radio"/>

• Actual accessories may vary from shown or change without notice.
Available accessories may vary by market.

Accessories

Note:

- Test an accessory on a small, inconspicuous area before use on sensitive surfaces.
- The “Product Components” page shows which accessories are included with your purchase.
- As shown below, there are many components compatible with this model. If you would like to purchase accessories or consumables, please contact Customer Service on **AUS: 1800 815 270, NZ: 0800 282 288.**

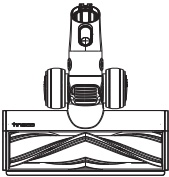

Direct-drive LED multi-tasker power brush

Direct-drive technology increases cleaning efficiency and ensures a highly dynamic clean; very effective for cleaning fine dust and debris on the carpet and hard floor. LED headlights help you clean the hard-to-see spots.

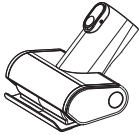

Mini power brush

For vacuuming upholstered furniture, mattresses etc. Vacuums pet hair and removes ingrained dirt.

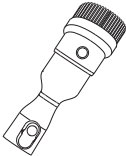

2-in-1 dusting brush

Switches between a wide and a soft brush by pressing the release button. The soft brush is most effective on hard-surface furniture while the wide brush is effective for upholstered furniture, curtains, etc.

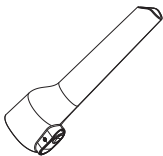

Crevice tool

For corners, nooks, and other hard-to-reach places such as around car seats, picture frames, and cupboards.



Soft dusting brush

Angled bristles on a slender, oval-shaped rim provide anti-static, cushioned contact. Suitable for dusting shelves, lighting, delicate surfaces, electronics and more.

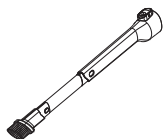

Flexible long crevice tool

Easy to bend, easy to reach tight spots. Suitable for cleaning dust behind and beneath furniture, around refrigerators, and many other tight gaps.

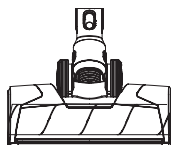

Full-size LED soft-roller power brush

Perfect for hard floors, especially sensitive wood floor. Picks up coarse and fine dirt at the same time.

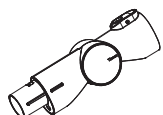

Multi-angle folding tube

An articulated joint makes it adjustable to allow for flexibility when cleaning from high to low.

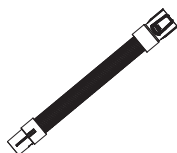

Flexible extension hose

Excellent extension and flexibility to access hard-to-reach spaces; perfect for in-care use. Compatible with all non-motorized Tineco accessories.

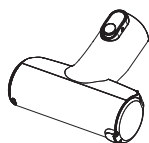

Automatic pre-filter cleaning tool

A dirty filter is a leading cause of suction loss, and this tool is designed to make your filter last much longer. Simply place the dirty filter inside the automatic pre-filter cleaning tool and close the lid. Connect the tool to the main body and pull the trigger. The appliance will automatically shut off once the task is complete.



Hair cleaning tool

Use the end with the small blade to remove hair and debris wrapped around the roller. Use the end with the brush to clean the brush window, and the dustbin, as required.

Assembly

Tube Installation

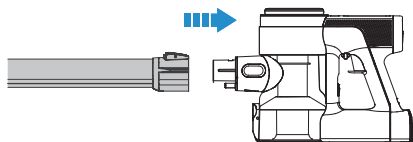

Insert tube.

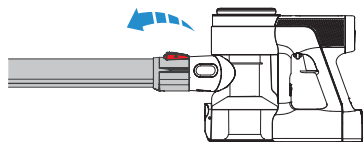

Press the release button and remove tube.

Brush Installation

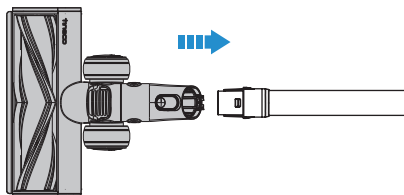

Insert the power brush.

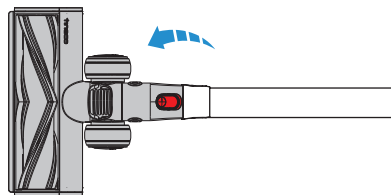

Press the release button and remove power brush.

Dustbin Installation

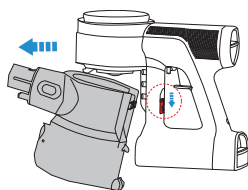

To clean the dustbin more thoroughly, press the dustbin release button to fully detach from the appliance.

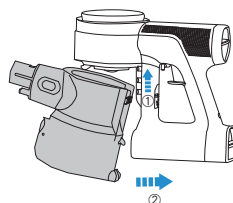

When re-attaching the dustbin, hold on an angle and slot the top of the dustbin into the hook on the main body. Push upwards until the hook is fixed into the slot on the dustbin and then it clicks into place.

Battery Installation

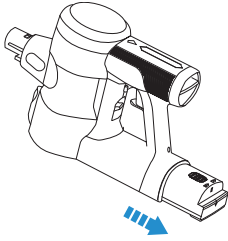

Press the battery release button, and remove the battery.

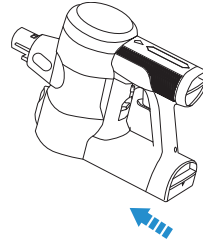

To replace, slide the battery into the slot at the base of the main body. The battery will click into position when correctly fitted.

Wall-mounted Dock Installation

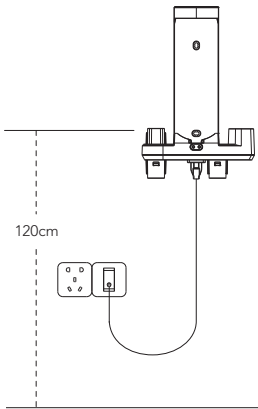

Determine the best wall location for mounting the dock. We recommend placing it 120cm from the lower screw hole to the floor (may need to be adjusted based on the actual situation).

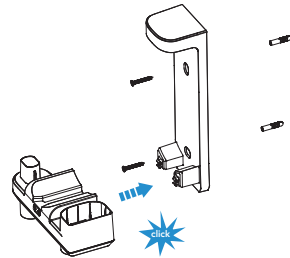

Assemble the two bracket components, with a "click" to signify correct assembly. Once this is complete, use the screws provided by Tineco to affix the dock to the wall.

Warning:

- Ensure the wall surrounding the mounting area is free of gas, water pipes, electrical cables and wires.
- To avoid the dock falling, ensure it is firmly installed.

Operation

Preparing for Use

Note:

- Before the first use, please charge the appliance (see "Charging the Battery") for 3-4 hours in an area where the ambient temperature is between 4°C (39.2°F) and 40°C (104°F).
- Select an accessory and attach it to the appliance before use (see "Accessories").

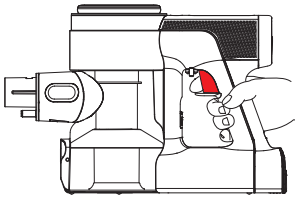

Pull the trigger to activate the suction.

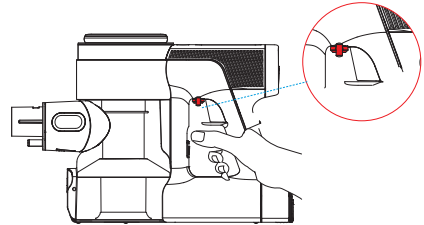

Pull the trigger lock to hold the trigger for continuous power mode.

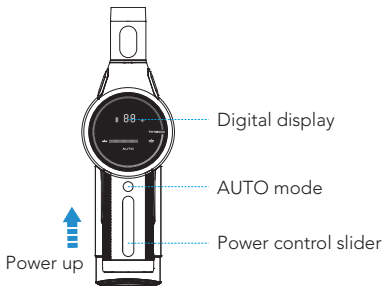

The appliance will start in AUTO mode by default. Swipe the power control slider to switch to Manual mode. Long-press the AUTO button to switch back to AUTO mode.

Cleaning Mode Selection

AUTO Mode

- In AUTO mode, the power indicator and the color of dust monitoring loop change according to the amount of dust detected. A red dust monitoring loop indicates more dust is detected whereas a blue loop indicates less is detected. This mode automatically provides the best cleaning solution.

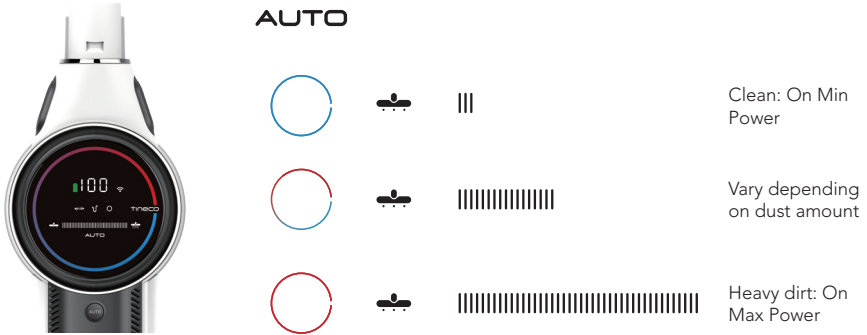

- Keep sharp objects away from the digital display to avoid scratches and scrapes.

To enter AUTO mode:

①

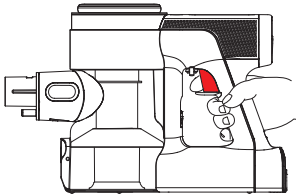

The default setting on startup is AUTO. The appliance then takes 3 seconds to initially detect blockages or dust. If no dust is detected, power is reduced to conserve energy.

②



When in Manual mode, press AUTO for 2 seconds until the AUTO indicator illuminates.

Manual Mode

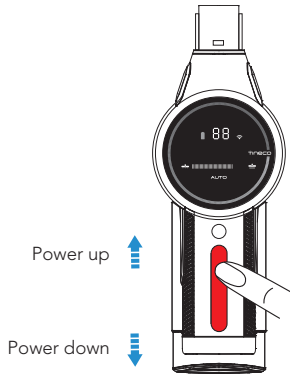

From AUTO mode, swipe the power control slider to switch to Manual mode. In Manual mode, you can control the power as needed.

Note:

Only use with dry hands. Dirty hands may affect slider operation.

APP

- All the functions can be performed using the Tineco app. Download the Tineco app from the App Store, Google Play and Tineco Official Site.

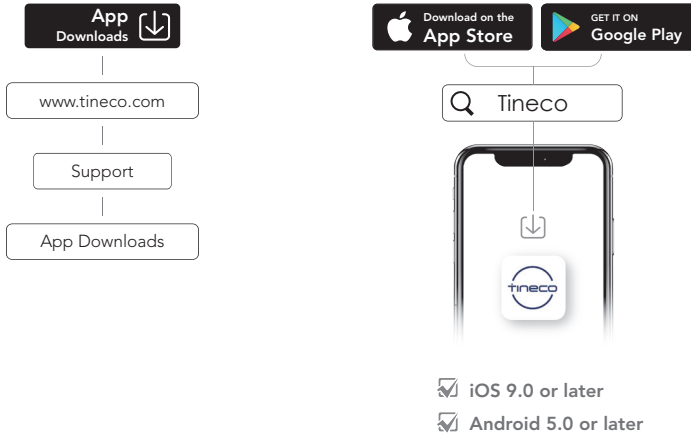

App Function Introduction



Battery

Battery level in real time.



Cleaning report

Displays the dust amount, working hours and working status.



Suction adjustment

When in manual mode, swipe the phone screen to adjust suction power.



Reminder of filter status

Records the severity of the dirty filter and provides a cleaning reminder as required.



Contact us

You can contact the Customer Service about any problems during the working hours.



Feedback

If you have any comments, please send us your feedback.

Emptying the Dustbin

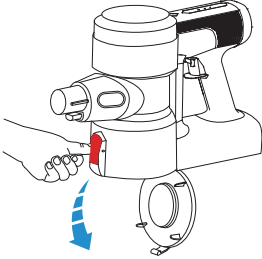

Press the release button on the side of the dustbin and empty the contents.

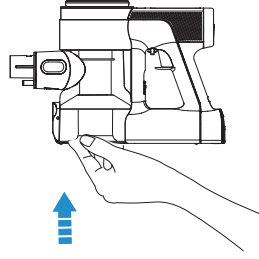

Close and click the dustbin flap back into place.

- Place the appliance on the wall-mounted dock for convenient storage and recharging after use.

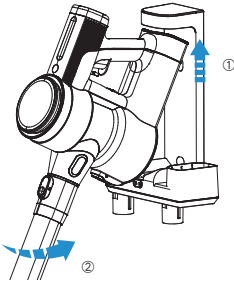

Place the main body on the dock.

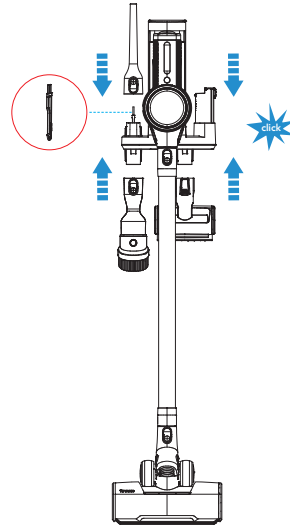

To avoid bristle damage, always place attachments on the dock after use.

Charging the Battery

- When secured on the wall-mounted dock, the battery attached to the main body will charge first, followed by the spare battery.

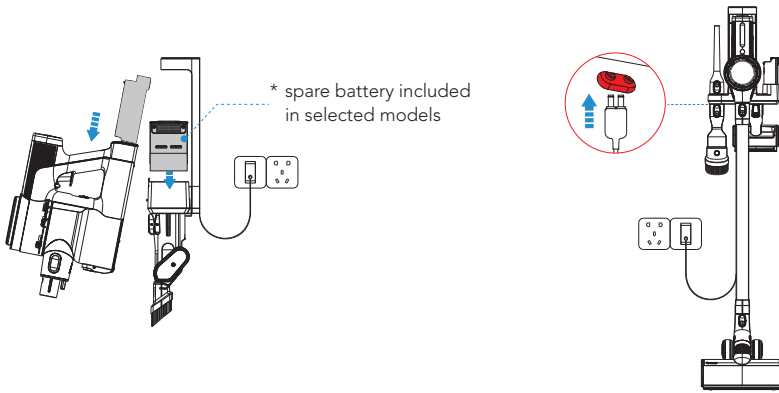

Connect the adaptor to the dock and outlet.

To charge, secure the main body and/or the spare battery on the dock. The battery can be recharged while attached to the main body, or separately.

Note:

- If you need a spare battery, please purchase from Tineco.



Warning:

- Only use the Tineco-provided adaptor to charge the battery.
- During long periods of not being used, store the lithium battery in a cool, dry place. Ensure the battery is half-charged every 3 months (Battery level > 50%).
- Store appropriately indoors in a dry place. Do not expose appliance to sunlight or freezing temperature. Recommended temperature range: 4°C (39.2°F)~40°C (104°F).

Runtime

- When in AUTO mode, the runtime is approximately 50 minutes. When MAX power is used, the runtime is approximately 10.5 minutes (for one battery).
- Estimated runtime data was obtained by a Tineco Laboratory using one battery and non-motorized accessories.

Charging Time

- A full charge takes approximately 3-4 hours for one battery.
- Estimated data was obtained by a Tineco Laboratory using ambient temperatures between 4°C (39.2°F) to 40°C (104°F).

Indicator

- For any of the following notifications, consult the “Troubleshooting” section of this manual.

When in Use



Battery level > 20%: solid green light.



Battery level ≤ 20%: solid red light.



Blinking red light: fault.



Blinking: brush roller has a blockage.



Blinking: appliance has a blockage, either in the filter or the dustbin.



Blinking: sensor inside the dustbin is obstructed, or the dustbin is not correctly installed.

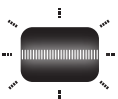

Blinking: motor failure.



Illuminated: WiFi has successfully connected.



Blinking: WiFi is connecting.



Off: WiFi is not connected, please connect.

During Charging

- The spare battery will only charge when the one attached to the main body has been fully charged (spare battery included in selected models).

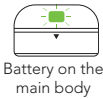

Charging (Battery level 0%~99%)

Battery icon: solid green.

Battery indicator: blinking green.

Tineco indicator: blinking.



Fully charged (Battery level up to 100%)

In 5 mins

Battery icon & Battery indicator: solid green.

Tineco indicator: illuminated.

After 5 minutes: all indicator lights turn off.



Battery icon blinking green:

No battery pack or battery pack installed incorrectly.

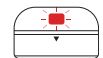

Both blinking red: fault.

Maintenance

Note:

- Clean the dustbin and filters after each use.
 - Use the cleaning tool to thoroughly clean the pre-filter when the indicator light shows a blocked air channel. To maintain high performance, wash and dry the pre-filter monthly, replacing it every 6 months.
- Wash and dry the HEPA filter every 3 months, replacing it every 12 months.

Dustbin and Mesh Filter

1

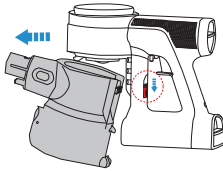

Press the dustbin release button to remove the dustbin.

2

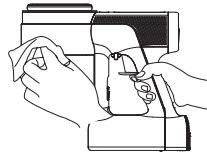

Clean with a damp cloth, taking care to prevent water entering the appliance main body and battery.

3

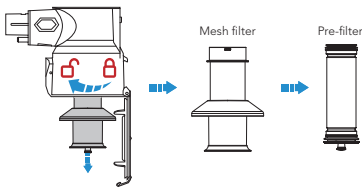

Turn counter-clockwise to remove the filters.

4

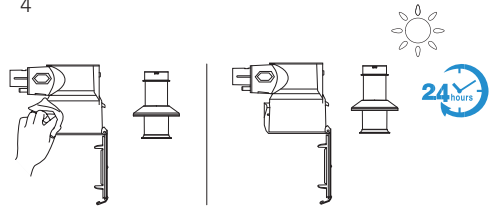

Clean the dustbin and mesh filter with a damp cloth. Air dry completely before reinstalling.

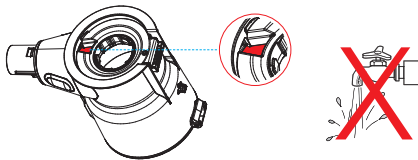

Warning:

- Do not wash the dustbin as it contains a dust sensor. If it comes into contact with water, please dry it with a hair dryer.

Pre-filter

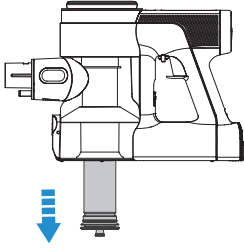

Ensure the appliance is switched off before cleaning, and remove the dirty pre-filter from the mesh filter-holder.

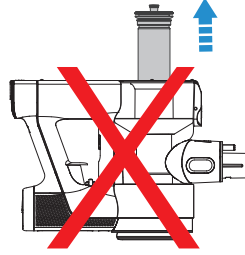

Do not turn the appliance upside down when removing or installing the filter to prevent dust from entering the motor.

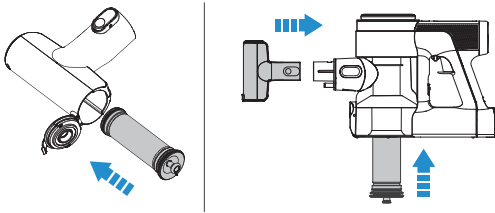

Replace a clean filter to the main body. Put the dirty pre-filter into the cleaning tool and connect the cleaning tool to the main body.

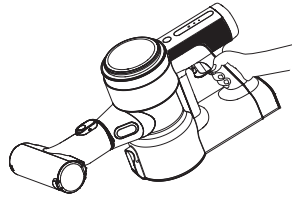

Activate the suction to clean the pre-filter. The appliance will automatically switch off after once cleaning is completed. Retain the clean pre-filter as a spare which can be reused.

HEPA Filter

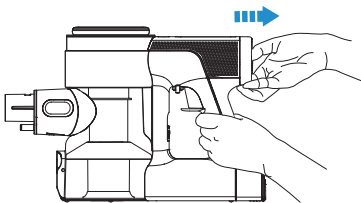

Press the HEPA release button and gently remove for cleaning. Do not use the appliance without first installing the HEPA filter.

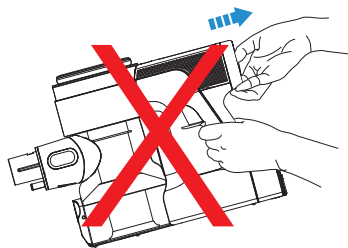

Do not place the appliance as above when removing or installing the HEPA filter, to prevent dust from entering the motor.

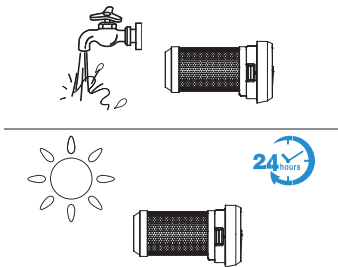

The HEPA filter can be washed under running water and must be completely dry before reinstalling.

Dust Sensor

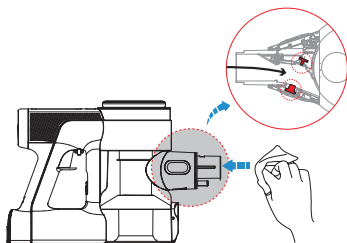

To avoid dust accumulation which can affect cleaning performance, wipe the suction mouth with a damp cloth.

Mini Power Brush

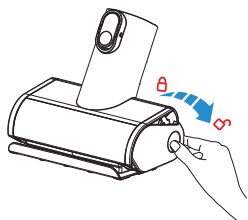

Press against the roller end cover downward.

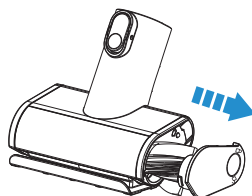

Pull out the brush roller.

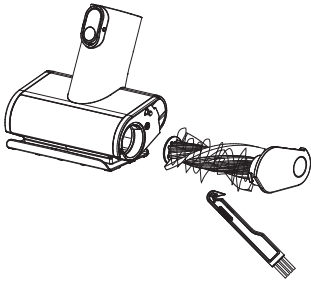

Remove the debris wrapped around the roller with the Tineco Hair Cleaning Tool.

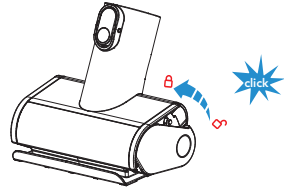

Fully reinsert the brush roller at an angle and push upward until it clicks securely back into place.

Brush Roller

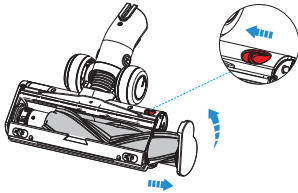

Slide the switch to open the brush roller end cover, and rotate it counter-clockwise to be able to pull out the brush roller.

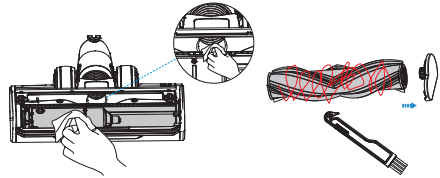

After removing the brush roller, gently clean the brush window and suction mouth. Remove the debris wrapped around the roller with the Tineco Hair Cleaning Tool.

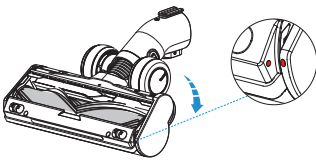

Fully reinsert the brush roller into the brush window and the end cover can be rotated clockwise until it clicks securely back into place.

Warning:

- The power brush contains electrical components which must not be soaked or washed with water.

Specifications









Product	PURE ONE S12 Platinum
Voltage	21.6V ===
Rated Power	500W
Dustbin Capacity	0.6L
Charging Time	3-4 hrs for one battery
AC Input	100-240V~
WiFi Frequency Bands	2.4G
WiFi Maximum Output Power	19dB

Disposal

- The battery contains materials that are harmful to the environment and must be removed from the appliance before it is discarded.
- When removing the battery, the appliance must be powered off.
- Batteries, chargers, accessories and packaging should be sorted for environmental friendly recycling. Do not put them into fire, water or soil. Do not dispose of batteries and chargers into household waste! 
- If battery leakage contacts skin or clothing, immediately flush with water to avoid irritation and seek medical help.

Troubleshooting

Problem	Possible cause	Solution
The appliance does not turn on	No power	Charge the battery
	Auto protection for overheating	Restart after cooling down
	The suction mouth is blocked	Check and remove blockages
Weak suction power	Dustbin and filters are full	Clean the dustbin and filters
	The pre-filter is not installed	Install the pre-filter
	The appliance is blocked (i.e. the tube, suction mouth or some other parts)	Remove blockages
	The brush roller tangled with hairs or fibers	Clean the brush roller
Abnormal motor sounds	The appliance is blocked (i.e. the tube, suction mouth or some other parts)	Remove blockages
Battery won't charge	The adaptor is not correctly inserted	Reinsert the adaptor correctly
	Insufficient contact between the main body and battery	Check the main body and battery are correctly placed
	The adaptor is not designed for PURE ONE S12	Use the original adaptor

Problem	Possible cause	Solution
Brush roller tangled indicator blinking 	The brush roller is blocked	Remove blockages
Power indicator blinking 	Motor failure	Remove blockages, or restart
Air channel blocked indicator blinking 	The appliance is blocked, or full of dust in filter and dustbin	Remove blockages, clean the filter and dustbin
Dust sensor malfunction indicator blinking 	1. The sensor inside the dustbin is blocked 2. The dustbin is not installed	1. Clean the dust on the inner sensor 2. Install the dustbin correctly
WiFi indicator is off 	WiFi is not connected	Follow the in-app guide to connect to WiFi
Battery indicator blinking red on work 	The battery is overheated	Remove the battery pack and let it cool
Battery indicator & Battery icon blinking red during charging  	Abnormal charging condition	The adaptor is not designed for PURE ONE S12
Battery icon on screen blinking green during charging 	No battery pack or battery pack installed improperly during charging	Install the battery on the main body properly

Note:

If the above troubleshooting guide fails to provide a solution, please contact Customer Service on customerservice@godfreys.com.au / customerservice@godfreys.co.nz or visit our website www.godfreys.com.au / www.godfreys.co.nz for further support.

Warranty

Your cleaner, in the case of domestic use, has a two year parts and labour warranty against product defects and failures when the product is used in accordance with the terms and conditions of this warranty statement.

This warranty commences from the original date of purchase and is not transferable; please retain your original proof of purchase for any warranty claims. This warranty is valid only in the country where the cleaner is purchased.

The cleaner must be operated in accordance with these instructions and used only for domestic household cleaning to remove DRY dirt and dust from household carpets, flooring and fabrics. This cleaner is not fit to be used as an industrial cleaner, and is not designed for the collection of vitreous building material including particle board, construction products and similar products such as wood/fibres, cement, fillers, fibre glass etc or excessive or frequent sand. The infrequent pick-up of these materials in these circumstances may be harmful to your cleaner and may void the manufacturer's warranty.

Accessories and consumables including dust bags and filters, unless defective in manufacture are not subject to this warranty. In order to prolong the life of accessories and consumables, regular care and maintenance is recommended.

When properly used and cared for, your cleaner will render excellent service; refer to the instruction manual for further details, as misuse or failure to follow the instructions makes this warranty void.

In the event of service or advice being needed, please contact Electrical Home-Aids Pty Ltd, Building 3, Level 1, Brandon Business Park, 530 Springvale Road, Glen Waverley Victoria 3150, on 1800 815 270 (AUS), 0800 282 288 (NZ), Monday-Friday 9am-5pm EST. The decision to repair or replace the cleaner is at the sole discretion of Electrical Home-Aids Pty Ltd. If Electrical Home-Aids Pty Ltd decide to repair or replace the cleaner, it will do so at its own cost.

Electrical Home-Aids Pty Ltd is unable to accept responsibility under this warranty for any repair work not carried out by an authorised Service Agent or from the use of non-genuine parts. If any part is no longer available or manufactured, Electrical Home-Aids Pty Ltd will replace it with a genuine functional replacement part. This warranty does not apply to the cost of replacing any parts of the product due to normal wear and tear, alterations, improper installation, physical abuse, misuse or accidental damage. Any transportation costs involved in the repair of defective parts shall be borne by the claimant.

If proof of purchase cannot be provided at the time of a warranty claim or service, any work carried out on the cleaner is chargeable. The repair of the cleaner under this warranty does not extend the original period of warranty.

The benefits conferred by this warranty are in addition to all other rights and remedies in respect of the product as outlined under the Competition and Consumer Act and other State and Territory laws.

“Our goods come with guarantees that cannot be excluded in the Australian Consumer Law. You are entitled to a replacement or refund for a major failure and for compensation for any other reasonably foreseeable loss or damage. You are also entitled to have the goods repaired or replaced if the goods fail to be of acceptable quality and the failure does not amount to a major failure.”

Call our Customer Service:

AUS: 1800 815 270

NZ: 0800 282 288

Or email our Customer Service:

customerservice@godfreys.com.au

customerservice@godfreys.co.nz

Visit Official Website:

www.godfreys.com.au

www.godfreys.co.nz

tineco
Live Easy.
Enjoy Life.



tinecoglobal 

Tineco Official Site: www.tineco.com

Customer Support & Service Hotline

AUS: 1800 815 270

NZ: 0800 282 288

www.godfreys.com.au

www.godfreys.co.nz

Distributed in Australia & New Zealand by Electrical Home-Aids Pty Ltd (Godfreys)
Building 3, Brandon Business Park, 530 Springvale Road, Glen Waverley, VIC, 3150, Australia.